

## Medium Pressure Filter

Pi 360

Nominal pressure 210/315 bar (2990/4480 psi), nominal size up to 450

### 1. Features

#### High performance filters for modern hydraulic systems

- Provided for pipe installation
- Modular system
- Compact design
- Minimal pressure drop through optimal flow design
- Visual/electrical/electronic maintenance control
- Threaded connections
- Change over valve on upstream side
- Ergonomic switch-over handle with safety lock and pressure compensation
- User-optimized one-hand-operation
- Equipped with highly efficient glass fibre Sm-x filter elements
- Beta rated elements according to ISO 16889 multipass test
- Elements with high differential pressure stability and dirt holding capacity
- NPT- and SAE-connections on request
- Worldwide distribution



## 2. Flow rate/pressure drop curve complete filter

■ 190 mm<sup>2</sup>/s (25° E)  
■ 33 mm<sup>2</sup>/s (4,5° E)

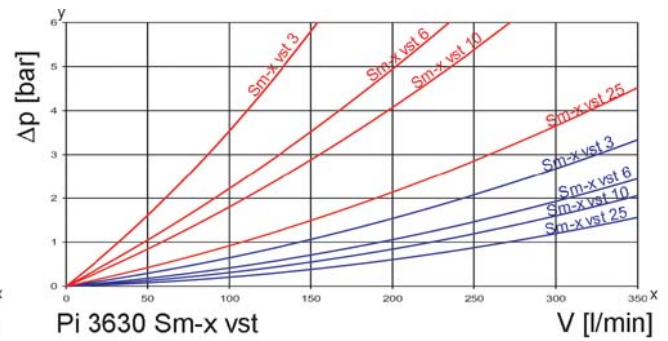
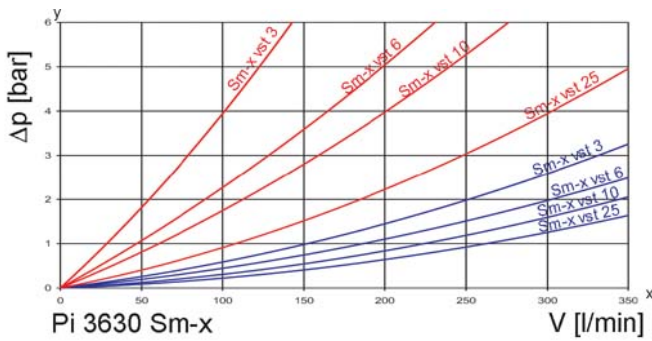
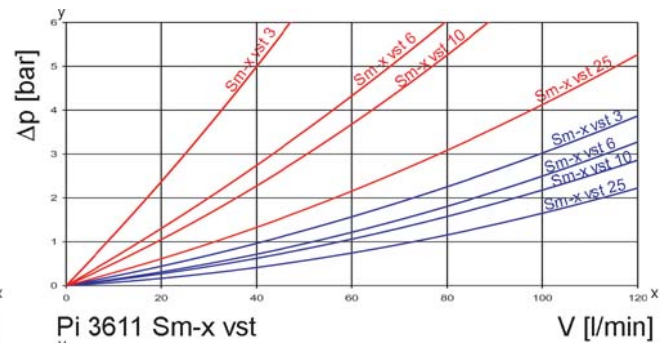
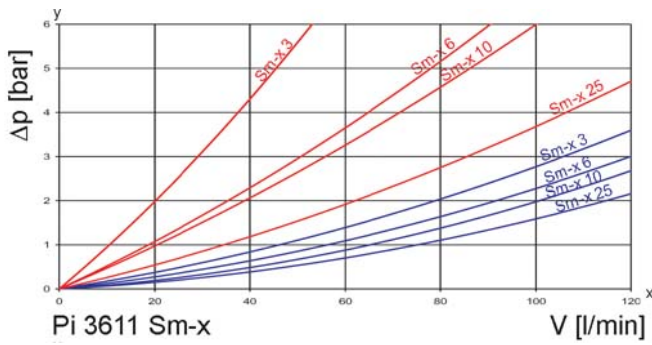
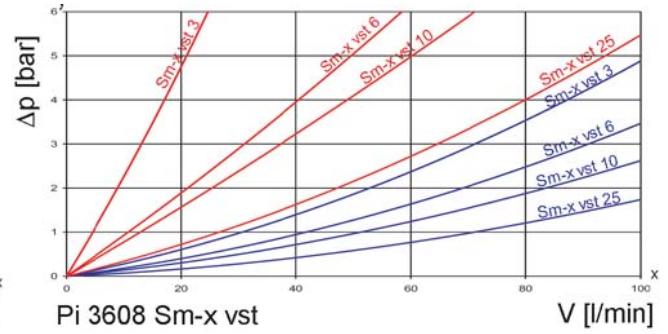
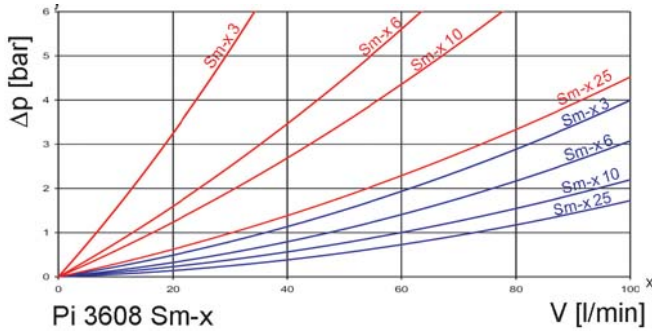
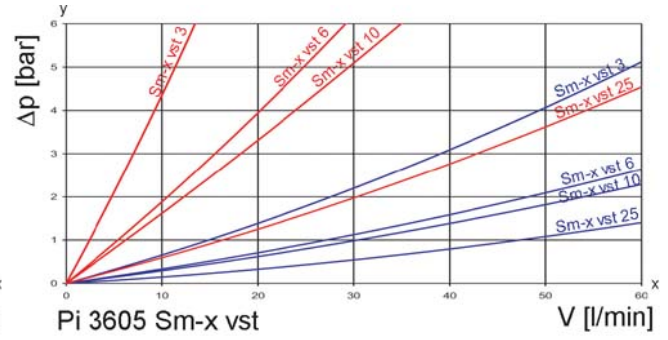
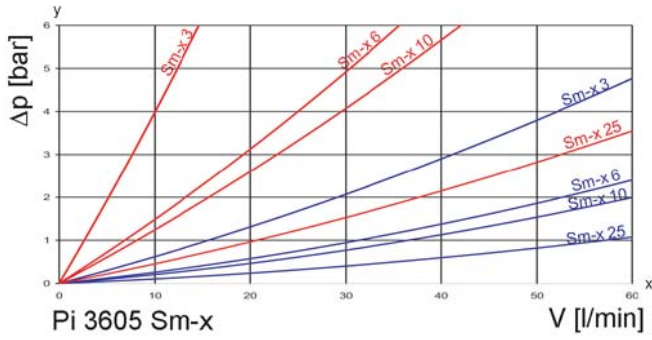

y = differential pressure  $\Delta p$  [bar]  
 x = flow rate V [l/min]

### 3. Separation grade characteristics

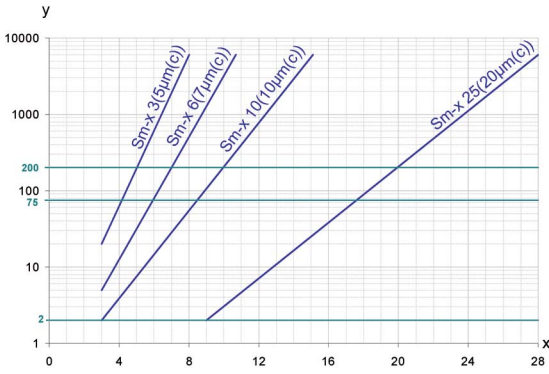

y = beta-value  
x = particle size [ $\mu\text{m}$ ]

determined by multipass tests (ISO 16889)  
calibration according to ISO 1171 (NIST)

### 4. Filter performance data

tested according to ISO 16889 (multipass test)

Sm-x elements with  
max.  $\Delta p$  20 bar

Sm-x	3	$\beta_{5(C)} \geq 200$
Sm-x	6	$\beta_{7(C)} \geq 200$
Sm-x	10	$\beta_{10(C)} \geq 200$
Sm-x	16	$\beta_{15(C)} \geq 200$
Sm-x	25	$\beta_{20(C)} \geq 200$

values guaranteed up to  
10 bar differential pressure

Sm-x vst elements with  
max.  $\Delta p$  210 bar

Sm-x vst	3	$\beta_{5(C)} \geq 200$
Sm-x vst	6	$\beta_{7(C)} \geq 200$
Sm-x vst	10	$\beta_{10(C)} \geq 200$
Sm-x vst	16	$\beta_{15(C)} \geq 200$
Sm-x vst	25	$\beta_{20(C)} \geq 200$

values guaranteed up to  
20 bar differential pressure

### 5. Quality assurance

MAHLE filters and filter elements are produced according to the following international standards:

Norm	Designation
DIN ISO 2941	Hydraulic fluid power filter elements; verification of collapse/burst resistance
DIN ISO 2942	Hydraulic fluid power filter elements; verification of fabrication integrity
DIN ISO 2943	Hydraulic fluid power filter elements; verification of material compatibility with fluids
DIN ISO 3723	Hydraulic fluid power filter elements; method for end load test
DIN ISO 3724	Hydraulic fluid power filter elements; verification of flow fatigue characteristics
ISO 3968	Hydraulic fluid power filters; evaluation of pressure drop versus flow characteristics
ISO 10771.1	Fatigue pressure testing of metal containing envelopes in hydraulic fluid applications
ISO 16889	Hydraulic fluid power filters; multipass method for evaluation filtration performance of a filter element

### 6. Symbols

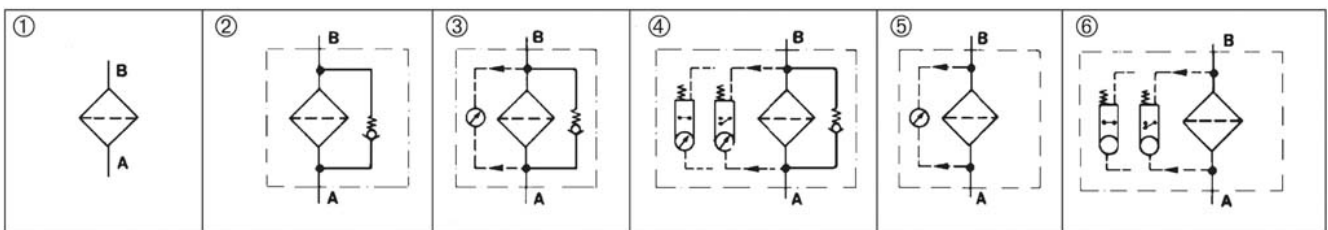

## 7. Order numbers

Example for ordering filters:

<p><b>1. Filter housing</b>  V=80 l/min and electrical maintenance indicator  Type: Pi 3608-15  Order number: 77666282</p>	<p><b>2. Filter element</b>  Sm-x vst 3  Type: Pi 2208 Sm-x vst 3  Order number: 77680200</p>
--	---

### 7.1 Housing design

Nominal size NG [l/min]	Order number	Type	① no options	② with bypass and indicator cavity	③ with bypass and visual indicator	④ with bypass and electrical indicator	⑤ with visual indicator	⑥ with electrical indicator
50	77655996	Pi 3605-060						
	77666217	Pi 3605-011						
	77666225	Pi 3605-012						
	77656044	Pi 3605-013						
	77666233	Pi 3605-014						
	77666241	Pi 3605-015						
80	77656002	Pi 3608-060						
	77666258	Pi 3608-011						
	77666266	Pi 3608-012						
	77656036	Pi 3608-013						
	77666274	Pi 3608-014						
	77666282	Pi 3608-015						
110	77656010	Pi 3611-060						
	77666290	Pi 3611-011						
	77666308	Pi 3611-012						
	77656028	Pi 3611-013						
	77731821	Pi 3611-014						
	77666316	Pi 3611-015						
150	77647845	Pi 3615-060						
	77731854	Pi 3615-011						
	77666324	Pi 3615-012						
	77655988	Pi 3615-013						
	77731862	Pi 3615-014						
	77731847	Pi 3615-015						
300	77655970	Pi 3630-060						
	77731896	Pi 3630-011						
	77666332	Pi 3630-012						
	77647837	Pi 3630-013						
	77731904	Pi 3630-014						
	77731888	Pi 3630-015						
450	70328126	Pi 3645-060						
	79343153	Pi 3645-011						
	79350810	Pi 3645-012						
	77883648	Pi 3645-013						
	79343161	Pi 3645-014						
	78299307	Pi 3645-015						

When filter with non bypass configuration is selected, the collapse pressure of the element must not be exceeded.

**7.2 Filter elements (a wider range of element types is available on request)**

Nominal size NG [l/min]	Order number	Type	Filter material	max. $\Delta p$ [bar]	Filter surface [cm <sup>2</sup> ]
50	77680135	Pi 2105 Sm-x 3	Sm-x 3	20	590
	77943509	Pi 5105 Sm-x 6	Sm-x 6		590
	77680325	Pi 3105 Sm-x 10	Sm-x 10		590
	77680440	Pi 4105 Sm-x 25	Sm-x 25		590
	77680192	Pi 2205 Sm-x vst 3	Sm-x vst 3	210	425
	77943533	Pi 5205 Sm-x vst 6	Sm-x vst 6		425
	77680382	Pi 3205 Sm-x vst 10	Sm-x vst 10		425
	77680507	Pi 4205 Sm-x vst 25	Sm-x vst 25		425
80	77680143	Pi 2108 Sm-x 3	Sm-x 3	20	1150
	77943517	Pi 5108 Sm-x 6	Sm-x 6		1150
	77680341	Pi 3108 Sm-x 10	Sm-x 10		1150
	77680457	Pi 4108 Sm-x 25	Sm-x 25		1150
	77680200	Pi 2208 Sm-x vst 3	Sm-x vst 3	210	850
	77943541	Pi 5208 Sm-x vst 6	Sm-x vst 6		850
	77681190	Pi 3208 Sm-x vst 10	Sm-x vst 10		850
	77680515	Pi 4208 Sm-x vst 25	Sm-x vst 25		850
110	77680150	Pi 2111 Sm-x 3	Sm-x 3	20	1700
	77943525	Pi 5111 Sm-x 6	Sm-x 6		1700
	77680333	Pi 3111 Sm-x 10	Sm-x 10		1700
	77680465	Pi 4111 Sm-x 25	Sm-x 25		1700
	77680218	Pi 2211 Sm-x vst 3	Sm-x vst 3	210	1275
	77943558	Pi 5211 Sm-x vst 6	Sm-x vst 6		1275
	77680390	Pi 3211 Sm-x vst 10	Sm-x vst 10		1275
	77680523	Pi 4211 Sm-x vst 25	Sm-x vst 25		1275
150	77680168	Pi 2115 Sm-x 3	Sm-x 3	20	2425
	77955099	Pi 5115 Sm-x 6	Sm-x 6		2425
	77680358	Pi 3115 Sm-x 10	Sm-x 10		2425
	77680473	Pi 4115 Sm-x 25	Sm-x 25		2425
	77680226	Pi 2215 Sm-x vst 3	Sm-x vst 3	210	2010
	77955123	Pi 5215 Sm-x vst 6	Sm-x vst 6		2010
	77680408	Pi 3215 Sm-x vst 10	Sm-x vst 10		2010
	77680531	Pi 4215 Sm-x vst 25	Sm-x vst 25		2010
300	77680176	Pi 2130 Sm-x 3	Sm-x 3	20	4620
	77955107	Pi 5130 Sm-x 6	Sm-x 6		4620
	77680366	Pi 3130 Sm-x 10	Sm-x 10		4620
	77680481	Pi 4130 Sm-x 25	Sm-x 25		4620
	77680234	Pi 2230 Sm-x vst 3	Sm-x vst 3	210	3800
	77955131	Pi 5230 Sm-x vst 6	Sm-x vst 6		3800
	77680416	Pi 3230 Sm-x vst 10	Sm-x vst 10		3800
	77680549	Pi 4230 Sm-x vst 25	Sm-x vst 25		3800
450	77680184	Pi 2145 Sm-x 3	Sm-x 3	20	6865
	77955115	Pi 5145 Sm-x 6	Sm-x 6		6865
	77680374	Pi 3145 Sm-x 10	Sm-x 10		6865
	77680499	Pi 4145 Sm-x 25	Sm-x 25		6865
	77680242	Pi 2245 Sm-x vst 3	Sm-x vst 3	210	5600
	77955149	Pi 5245 Sm-x vst 6	Sm-x vst 6		5600
	77680424	Pi 3245 Sm-x vst 10	Sm-x vst 10		5600
	77680556	Pi 4245 Sm-x vst 25	Sm-x vst 25		5600



## 8. Technical specifications

Design:	line mounting filter
Nominal pressure: Pi 3615-3645	210 bar (2990 psi)
Pi 3605, 3608, 3611	315 bar (4480 psi)
Test pressure: Pi 3615-3645	275 bar (3910 psi)
Pi 3605, 3608, 3611	410 bar (5830 psi)
Temperature range:	-10 °C to +120 °C
	(other temperature ranges on request)
Bypass setting:	$\Delta p$ 7 bar $\pm$ 10 %
Filter head material:	GGG
Filter housing material:	St
Sealing material:	NBR/PTFE
Maintenance indicator setting:	$\Delta p$ 5 bar $\pm$ 10 %
Electrical data of maintenance indicator:	
Max. voltage:	250 V AC/200 V DC
Max. current:	1 A
Contact load:	70 W
Type of protection:	IP 65 in inserted and secured status
Contact:	normally open/closed
Cable sleeve:	M20x1.5

The switching function can be changed by turning the electric upper part by 180° (normally closed contact or normally open contact). The state on delivery is a normally closed contact. By inductivity in the direct current circuit the use of suitable protection circuit should be considered. Further maintenance indicator details and designs are available in the maintenance indicator data sheet.

We draw attention to the fact that all values indicated are average values which do not always occur in specific cases of application. Our products are continually being further developed. Values, dimensions and weights can change as a result of this. Our specialized department will be pleased to offer you advice.

We recommend to contact us concerning applications of filters in areas governed by the EU Directive 94/9 EC (ATEX 95). The standard version can be used for liquids based on mineral oil (corresponding to the fluids in Group 2 of Directive 97/23 EC Article 9). If you consider to use other fluids please contact us for additional support.

Subject to technical alteration without prior notice.

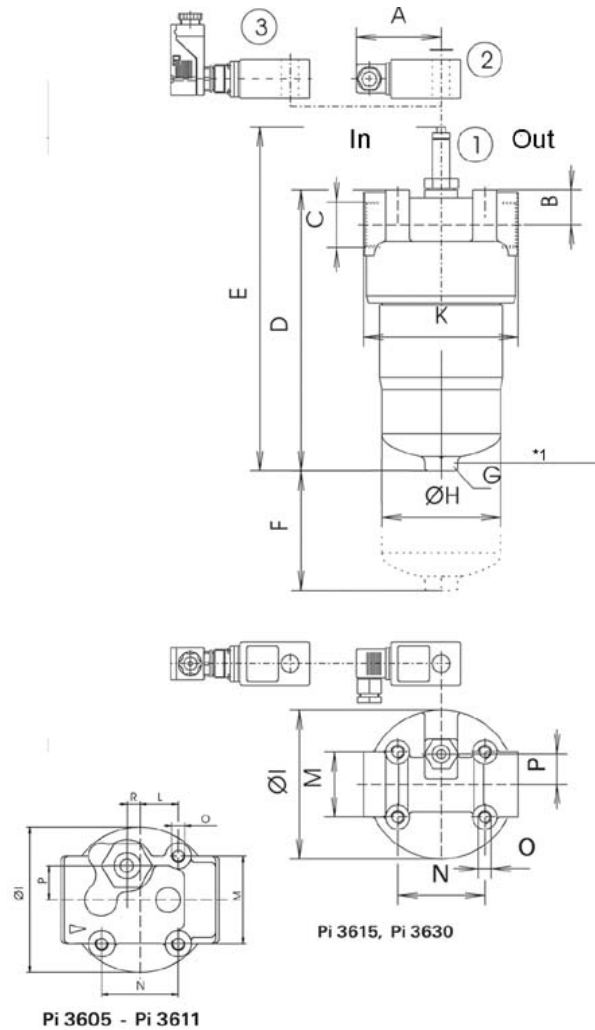

In = inlet  
 Out = outlet  
 Pos 1 - Visual maintenance indicator  
 Pos 2 - Electrical upper section connector according DIN EN 175301-803  
 Executions: Pis 3092, 3105, 3115  
 Pos 3 - Electrical upper section connector according DIN EN 175201-804  
 Executions: Pis 3102, 3122, 3110, 3132

\*1 NG 300 and NG 450 with drain screw G $\frac{1}{4}$

## 9. Dimensions

All dimensions except "C" in mm.

Type	A	B	C*	D	E	F	G SW	H	I	K	L	M	N	O	P	R	Weight [kg]
Pi 3605	78	31	G $\frac{1}{2}$	189	247	80	27	66	90	92	23.5	54	47	M8x16	21	8	4.1
Pi 3608	78	31	G $\frac{3}{4}$	267	325	80	27	66	90	92	23.5	54	47	M8x16	21	8	5.0
Pi 3611	78	31	G $\frac{3}{4}$	343	401	80	27	66	90	92	23.5	54	47	M8x16	21	8	5.9
Pi 3615	78	32	G1 $\frac{1}{4}$	259	315	110	30	109	137	142	-	60	80	M12x16	28	-	9.8
Pi 3630	78	32	G1 $\frac{1}{4}$	384	440	110	30	109	137	142	-	60	80	M12x16	28	-	12.5
Pi 3645	78	32	G1 $\frac{1}{4}$	400	556	110	30	109	137	142	-	60	80	M12x16	28	-	14.0

\* NPT- and SAE- port connections on request

## 10. Installation, operating and maintenance instructions

### 10.1 Filter installation

When installing the filter make sure that sufficient space is available to remove filter element and filter housing. Preferably the filter should be installed with the filter housing pointing downwards.

The maintenance indicator must be visible.

### 10.2 Connecting the electrical maintenance indicator

The electrical indicator is connected via a 2-pole appliance plug according to DIN EN 175301-803 with poles marked 1 and 2. The electrical section can be inverted to change from normally open to normally closed position or vice versa.

### 10.3 When should the filter be replaced?

- Filters equipped with visual and electrical maintenance indicator:  
During cold starts, the indicator may give a warning signal. Press the red button of the visual indicator once again only after operating temperature has been reached. If the red button immediately pops up again and/or the electrical signal has not switched off after reaching operating temperature. The filter element must be replaced after the end of the shift.
- Filters without maintenance indicator: The filter element should be replaced after trial run or flushing of the system. Afterwards follow instructions of the manufacturer.
- Please always ensure that you have original MAHLE spare elements in stock: Disposable elements SM-x cannot be cleaned.

### 10.4 Element replacement

- Stop system and relieve filter from pressure.
- Unscrew the filter housing by turning counter-clockwise. Clean the housing using a suitable cleaning solvent.
- Remove element by pulling down carefully.
- Check o-ring and back-up ring on the filter housing and spigot for damage. Replace, if necessary.
- Make sure that the order number on the spare element corresponds to the order number of the filter plate.  
To ensure no contamination occurs during the exchange of the filter element first open the plastic bag and push the element over the spigot in the filter head. Now remove plastic bag.
- Lightly lubricate the thread of the filter housing and screw onto the filter head completely. After that unscrew the filter housing 1/8 to 1/2 turn.

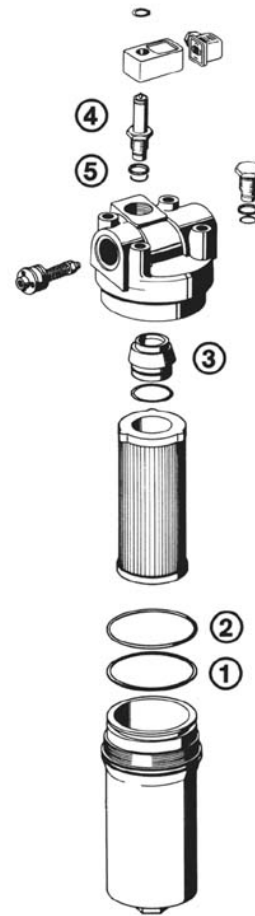

## 11. Spare parts list

Order numbers for spare parts		
Position	Type	Order number
① - ③	Seal kit	
	<b>Pi 3605 - Pi 3611</b>	
	NBR	77637150
	FPM	77637168
	EPDM	77637176
	<b>Pi 3615 - Pi 3645</b>	
	NBR	77637184
	FPM	77637192
	EPDM	77637200
④	Maintenance indicator	
	Visual PiS 3093/5	77669914
	Visual/electrical PiS 3092/5	77669864
	Electrical upper section only	77536550
⑤	Seal kit for maintenance indicator	
	NBR	77760275
	FPM	77760283
	EPDM	77760291



*Industrial Filtration*

MAHLE Filtersysteme GmbH  
Industriefiltration  
Schleifbachweg 45  
D-74613 Öhringen  
Phone +49 (0) 7941/67-0  
Fax +49 (0) 7941/67-23429  
industriefiltration@mahle.com  
www.mahle-industriefiltration.com  
78356834.03/2008